

Installation and Setup Guide

The PROSiXTEMP is a wireless temperature sensor intended for use with Honeywell Home controls that support PROSiX™ series devices. The sensor sends an alarm or trouble signal (depending on zone type selected; ex. Monitor Zone or 24hr Aux) when the temperature limit is exceeded. The sensor also features a front cover tamper switch.

Default Temperature Limits

	Trigger Temperature
Cold	below 45°F (7°C)
Hot	above 95°F (35°C)

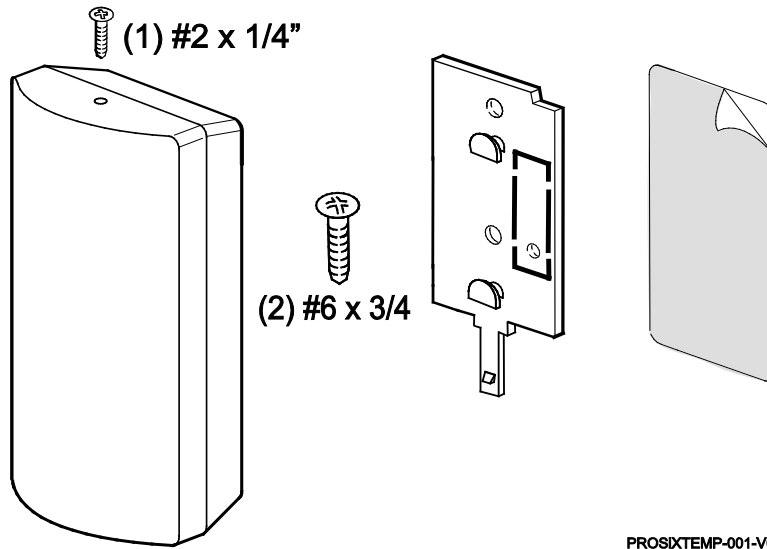

MOUNT THE PROSiXTEMP

1. To open the case, firmly slide the front and back housings in opposite directions and pull them apart.
2. Mount sensor as shown, using the double sided tape and screws provided.
3. Secure the front cover with the #2 x 1/4" screw.

After enrolling and before mounting, verify adequate signal strength by conducting a sensor test (see controller's instructions) with the device in its intended mounting location. Adjust the device location and orientation as necessary.

A = Tamper Switch

B = LED

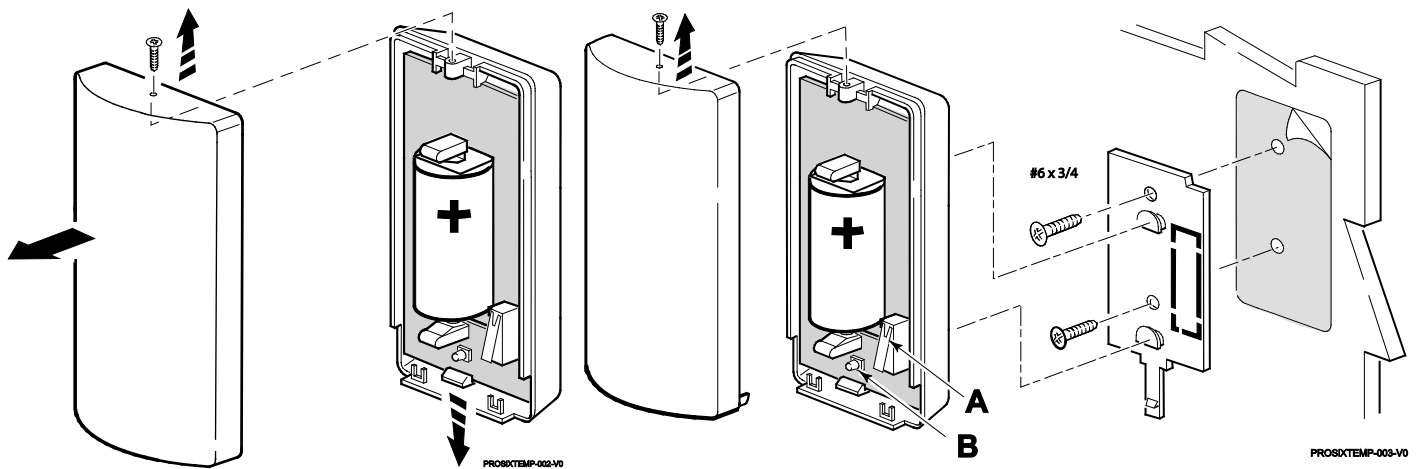

ENROLL AND SETUP

Set the controller in Programming Mode, when prompted:

1. Pull the battery tab to activate the PROSiXTEMP. (Use the tamper switch if the battery tab is removed.)
2. The LED flashes (up to about 20 seconds*) during enrollment.
 - The device is automatically enrolled in the next available zone number.
 - The device requires two zones, one for the high temperature and one for the low temperature.
 - The device sends its unique MAC ID (Serial Number); the controller registers the device and displays the transmitter data on screen.

***NOTE:** Enrollment time varies depending on the signal strength between the device and the controller.

3. When done, the LED is ON for 3 seconds to confirm enrollment.

NOTE: If the device is not successfully enrolled during the enrollment period, the LED turns off and the device powers down. Activate the tamper switch to restart the enrollment process.

You must enroll the device in the control. Refer to the control's programming instruction for detailed procedures.

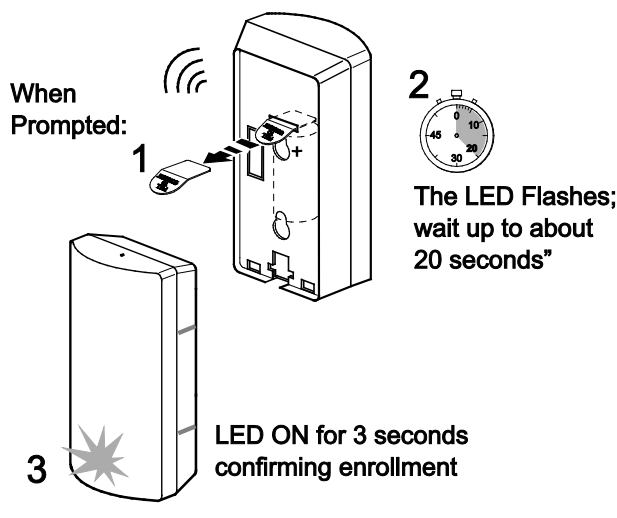

IMPORTANT: Once enrolled in a system, the PROSiXTEMP cannot be used with another controller until it is removed from the current controller. See the Controller's instructions for details.

24-HOUR ENROLLMENT DELETION AND DEFAULT

If the device is enrolled in a panel different than the intended panel, and you are unable to delete it from the unintended panel, reset the device to factory default setting:

1. Open the cover and remove the battery.
2. Hold down the tamper switch while reinserting the battery. Rapid LED flashing indicates successful deletion (LED flashes as if in enrollment mode). If LED does not flash, delete was not successful.
3. Reattach the cover.

This procedure is available for 24 hours after enrollment with a panel and the device remains powered (battery installed).

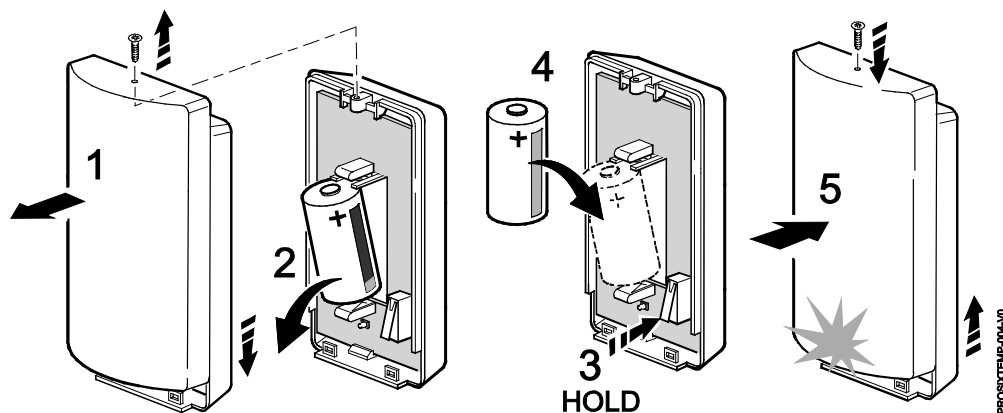

LED INDICATIONS

○ = ON ☉ = Slow Flash ☉☉ = Rapid Flash

LED	Status
☉☉ → ○	Rapid Flashes for about 20 seconds, then ON for 3 seconds Power Up – Enrollment
☉	Slow Flashes Power Up – Device enrolled; Cover Tamper activated. To stop flashes, clear the tamper condition by reattaching the cover. It also times out after 10 minutes.
○ (while in Programming Mode)	ON Sensor LED toggles on and off when the sensor is selected. See Sensor Location Feature.

BATTERY REPLACEMENT

- Push the bottom latch of the mounting bracket back to disengage it. Then slide the back housing, up and out to remove it from the mounting bracket.
- Slide the front and back housings in opposite directions and pull the housings apart.
- Remove the battery, **wait 10 seconds**, then insert a new battery. Recommended batteries:
Resideo 466 Duracell DL123A
Huiderui CR123A Panasonic CR123A
- Place the front and back housings together and slide them together as shown.

BATTERY CAUTION: Risk of fire, explosion and burns. Do not recharge, disassemble, heat above 212°F (100°C) or incinerate. Dispose of used batteries properly. Keep away from children.

NOTE: Constant exposure to high or low temperature or high humidity may reduce battery life.

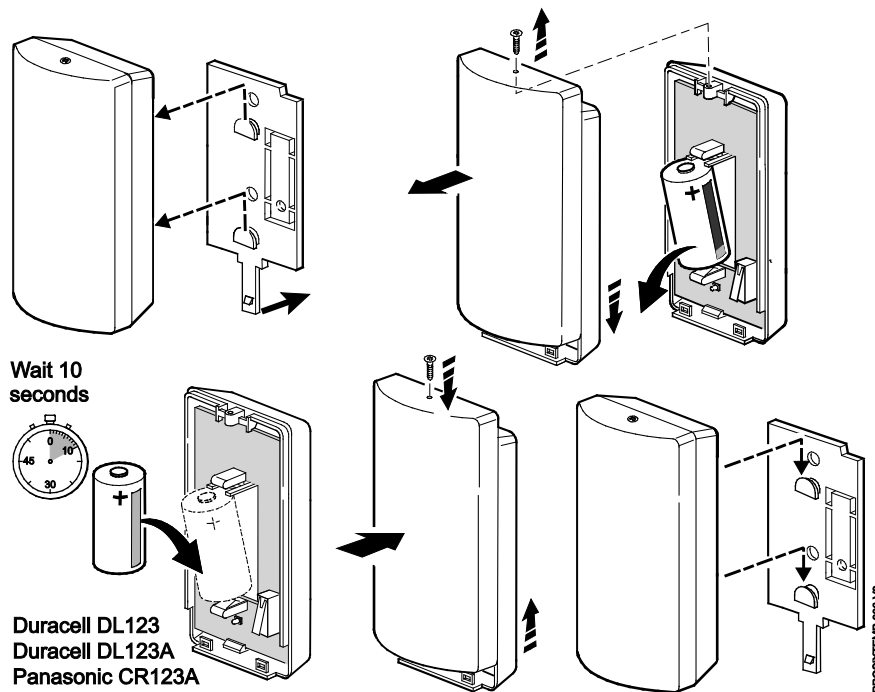

SPECIFICATIONS:

Battery: 1 x 3V Lithium, Panasonic CR123A, Resideo 466
Duracell DL123A or Huiderui CR123A

Tamper: Cover

RF Frequency: 2.4GHz

Operating Temperature: 32° – 122° F / 0° – 50° C
(Agency Compliance 32° – 120° F / 0° – 49° C)

Relative Humidity: 95% max. (Agency Compliance - 93% max.),
non-condensing

Dimensions: 1" H x 3.13" L x 1.61" W / 25.5 mm H x 79.5 mm L x 41 mm W

APPROVAL LISTINGS:

FCC / IC

cETLus Listed

Conforms to ANSI/UL 873 and
ANSI/UL 2017

Certified to CAN/CSA STD C22.2
#205

Other Standards:

RoHS

Product must be tested at
least once each year



FEDERAL COMMUNICATIONS COMMISSION & INDUSTRY CANADA STATEMENTS

The user shall not make any changes or modifications to the equipment unless authorized by the Installation Instructions or User's Manual. Unauthorized changes or modifications could void the user's authority to operate the equipment.

CLASS B DIGITAL DEVICE STATEMENT

This equipment has been tested to FCC requirements and has been found acceptable for use. The FCC requires the following statement for your information: This equipment generates and uses radio frequency energy and if not installed and used properly, that is, in strict accordance with the manufacturer's instructions, may cause interference to radio and television reception. It has been type tested and found to comply with the limits for a Class B computing device in accordance with the specifications in Part 15 of FCC Rules, which are designed to provide reasonable protection against such interference in a residential installation. However, there is no guarantee that interference will not occur in a particular installation. If this equipment does cause interference to radio or television reception, which can be determined by turning the equipment off and on, the user is encouraged to try to correct the interference by one or more of the following measures:

- If using an indoor antenna, replace it with a quality outdoor antenna.
- Reorient the receiving antenna until interference is reduced or eliminated.
- Move the radio or television receiver away from the receiver/control.
- Move the antenna leads away from any wire runs to the receiver/control.
- Plug the receiver/control into a different outlet so that it and the radio or television receiver are on different branch circuits.
- Consult the dealer or an experienced radio/TV technician for help.

INDUSTRY CANADA CLASS B STATEMENT

This Class B digital apparatus complies with Canadian ICES-003.
Cet appareil numérique de la classe B est conforme à la norme NMB-003 du Canada.

FCC / IC STATEMENT

This device complies with Part 15 of the FCC Rules, and Industry Canada's license-exempt RSSs. Operation is subject to the following two conditions: (1) This device may not cause harmful interference, and (2) This device must accept any interference received, including interference that may cause undesired operation.

Cet appareil est conforme à la partie 15 des règles de la FCC et exempt de licence RSS d'Industrie Canada. Son fonctionnement est soumis aux conditions suivantes: (1) Cet appareil ne doit pas causer d'interférences nuisibles. (2) Cet appareil doit accepter toute interférence reçue y compris les interférences causant une réception indésirable.

RF EXPOSURE

Warning – The antenna(s) used for this device must be installed to provide a separation distance of at least 7.8 inches (20 cm) from all persons and must not be co-located or operating in conjunction with any other antenna or transmitter except in accordance with FCC and ISED multi-transmitter product procedures.

Mise en garde

Exposition aux fréquences radio : La/les antenne(s) utilisée(s) pour cet émetteur doit/doivent être installée(s) à une distance de séparation d'au moins 20 cm (7,8 pouces) de toute personne et ne pas être située(s) ni fonctionner parallèlement à tout autre transmetteur ou antenne, excepté en conformité avec les procédures de produit multi transmetteur FCC et ISED.

REFER TO THE INSTALLATION INSTRUCTIONS FOR THE CONTROL WITH WHICH THIS DEVICE IS USED, FOR DETAILS REGARDING LIMITATIONS OF THE ENTIRE ALARM SYSTEM.

Responsible Party / Issuer of Supplier's Declaration of Conformity: Ademco Inc., a subsidiary of Resideo Technologies, Inc., 2 Corporate Center Drive., Melville, NY 11747, Ph: 516-577-2000

The product should not be disposed of with other household waste. Check for the nearest authorized collection centers or authorized recyclers. The correct disposal of end-of-life equipment will help prevent potential negative consequences for the environment and human health.

Any attempt to reverse-engineer this device by decoding proprietary protocols, de-compiling firmware, or any similar actions is strictly prohibited.

SUPPORT & WARRANTY INFORMATION

For the latest documentation and support, please go to:
www.resideo.com

For the latest warranty information, please go to:
www.security.honeywellhome.com/warranty

The Honeywell Home Trademark is used under license from Honeywell International Inc.
This product is manufactured by Resideo Technologies, Inc. and its affiliates.

resideo

2 Corporate Center Drive, Suite 100
P.O. Box 9040, Melville, NY 11747
© 2020 Resideo Technologies, Inc.
www.resideo.com



PROSiXTEMP 800-25252B 2/19 Rev B