

Installation and Setup Guide

This wireless siren/strobe is intended for use with Honeywell Home controls that support PROSiX™ series devices.

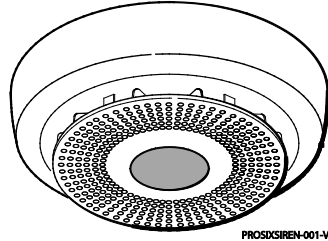

PROSiXSIREN

OPEN

Gently twist the top of the Siren counterclockwise and the mounting bracket clockwise to separate them.

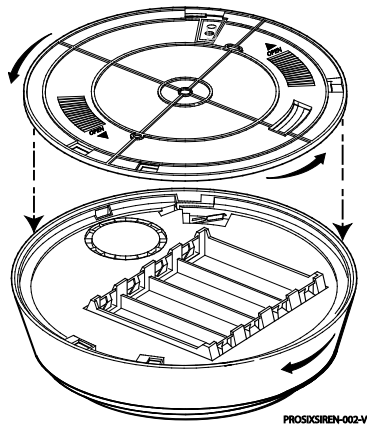

MOUNTING

The PROSiXSIREN can be mounted on the wall or on the ceiling.

The rear tamper breakout [A] MUST be mounted to a stud, solid wood, or with a robust wall anchor.

After enrolling, verify adequate signal strength by conducting sensor test (see controller's instructions) with the device in its intended mounting location. Adjust the device location and orientation as necessary.

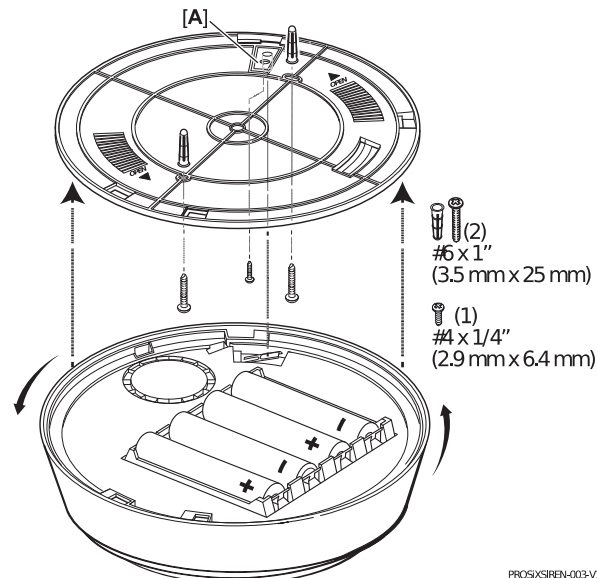

ENROLL

This device can be enrolled and programmed either before or after installation.

Set the control in Programming Mode and when prompted

1. Insert four 1.5V AA Lithium batteries (included) to activate the device and begin the enrollment process.
2. The Green LED flashes rapidly during enrollment (up to about 20 seconds*)
***NOTE:** Enrollment time varies depending on the signal strength between the device and the controller.
 - The device sends its unique MAC ID address (Serial Number) and Services information to the controller.
 - The controller registers the device and displays the transmitter data on screen.
3. Enrollment is confirmed when the Green LED is ON for 3 seconds.
4. The device did not enroll in the system if:
 - The White LED flashes, the system chirps and the device powers down.
 - The Green LED flashes rapidly when the device is removed from the mounting bracket (the tamper switch is triggered).

To restart the enrollment process, ensure the system is in programming mode and activate the tamper switch.

You must enroll the device in the control. Refer to the control's programming instruction for detailed procedures.

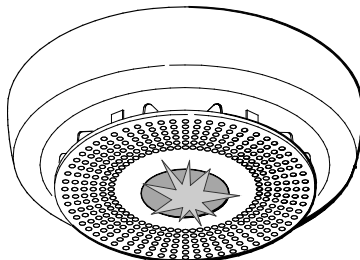

When prompted:

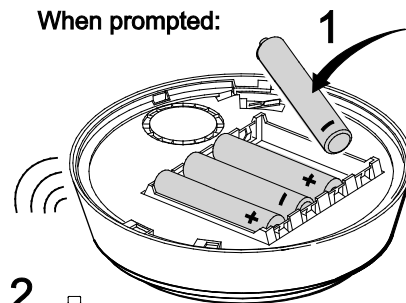

2



The LED Flashes; wait up to about 20 seconds.

3

The Green LED is ON for 3 seconds confirming enrollment.

PROSIXSIREN-004-V0

The device can also be manually enrolled. See the Controller's Programming Guide for details.

NOTE: Once enrolled in a system, the device cannot be used with another controller until it is removed from the current controller. See the Controller's instructions for details.

PROGRAM

See the Controller's instructions for programming the device in the system.

Refer to the LED and Sounder table for details of chime operation when the CHIME feature is enabled (factory default is enabled).

DEFAULT PROSIXSIREN

If the device is enrolled in a panel different than the intended panel, and you are unable to delete it from the unintended panel, default the device:

1. Open the cover and remove the batteries.
2. Hold down the tamper switch while reinserting the batteries.
3. Reattach the cover.

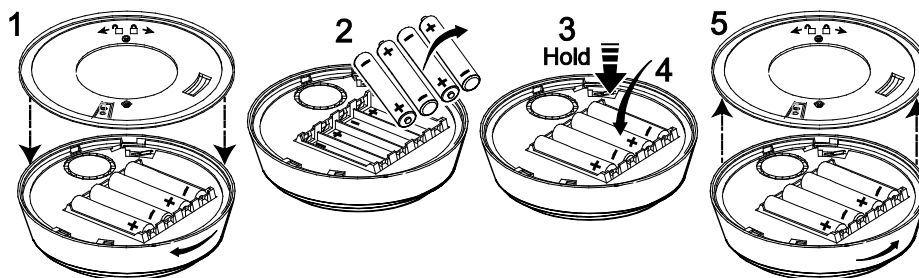

PROSIXSIREN-005-V0

This procedure is available for 24 hours after enrollment with a panel and the device remains powered (battery installed).

LEDS AND SOUNDER

Refer to the table below for operation of the four bi-colored LEDs and an 85dB sounder.

LEDS			Sounders	
R = Red	○ = ON	☀ = Rapid Flash	🔊 = Chirp	🔊🔊🔊 = Temporal Pulse 3
G = Green	⊗ = Slow Flash	☀☀ = Strobe Flash	🔊🔊🔊 = Burglary Warble	🔊🔊🔊🔊 = Temporal Pulse 4
W = White				

R / W	G / W	Sounder	Status
	☀ → ⊗	🔊 once	Power Up – Enrollment
	⊗	🔊 once	Power Up – Device enrolled
	⊗		System is Disarmed
Ⓜ Red ON for 20 seconds			System is Armed
☀ / ☀ (continues until the Alarm is cleared)		🔊🔊🔊	Smoke / Heat Alarm
		🔊🔊🔊	CO Alarm
Ⓜ White ON	Ⓜ White ON	🔊🔊🔊 3 seconds	Burglary Alarm
Ⓜ Red flashes once every 45 seconds		🔊 ²	Low Battery
	⊗ Green Flashes slowly for 10 minutes		Tamper Activated
Chime operation when the CHIME feature is enabled		🔊 x 1	The system is Disarmed
		🔊 x 2	The system is Armed, Away mode
		🔊 x 3	The system is Armed, Stay mode or a Zone was Faulted

¹ Strobe flash = two flashes per second, then OFF for 1 second.

² After 7 days, the sounder chirps once every 45 seconds until the batteries are replaced or die. See the Battery Replacement section.

TEST THE PROSIXSIREN

The PROSIXSIREN should be tested immediately after installation and weekly. Activate Test Mode remotely from the Controller (see Controller's manual for details). **The product must be tested at least once a year.**

Test Mode tests the sounder and LED:

- Sounder – the Burglary warble tone will sound for 3 seconds.
- LED – the White LED strobe will flash for 15 seconds.

BATTERY REPLACEMENT

- Twist the front cover counterclockwise and separate it from the mounting bracket.

- Remove the batteries, wait 10 seconds and **insert four new batteries of the same type and brand.**

Recommended replacement batteries:

- 1.5V AA Lithium Batteries [Non-Rechargeable]
- AA Alkaline batteries can be used, but battery life will be significantly reduced.

NOTE: Do not mix old and new batteries, battery types or manufacturers.

- Reattach the front cover and twist clockwise to secure it in place.

BATTERY CAUTION: Risk of fire, explosion and burns. Do not recharge, disassemble, heat above 212 F (100 C) or incinerate. Dispose of used batteries properly. Keep away from children.

NOTE: Constant exposure to high or low temperature or high humidity may reduce battery life.

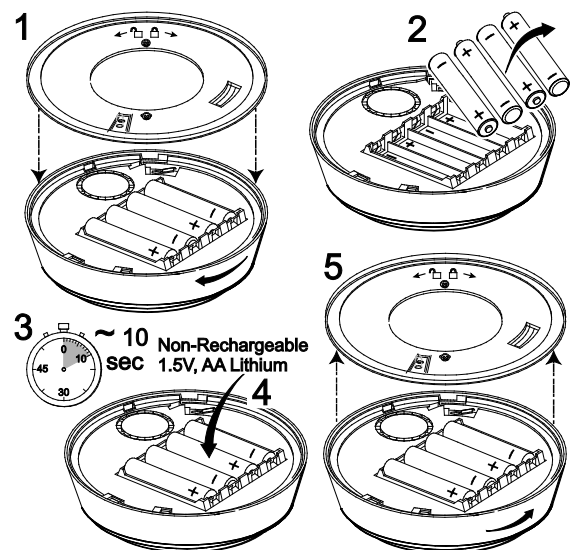

SPECIFICATIONS:

Range: 300 feet nominal indoors (actual range determined by the system in TEST mode)

Battery: Four 1.5V, AA Lithium, Non-Rechargeable; Energizer E², Resideo 462

Tamper: Cover and Wall tamper

RF Frequency: 2.4GHz

Input Voltage: 3,3VDC

Current: 339 mA, Typical

Siren Output Level: 85 dB at 10 feet

Operating Temperature: 0° to 50°C / 32° to 122°F (Agency Compliance 0° to 49°C / 32° to 120°F)

Relative Humidity: 95% max. (Agency compliance – 93% max), non-condensing

Dimensions: 14.14 cm Diameter x 4.62 cm Thick / 5.5 in. Diameter x 1.8 in. Thick

APPROVAL LISTINGS:

FCC / IC

cETLus Listed

Conforms to UL 985 /

UL 1023

Certified to ULC-S545 &

ULC/ORD-C1023

Other Standards:

RoHS



FEDERAL COMMUNICATIONS COMMISSION (FCC) & INDUSTRY CANADA (IC) STATEMENTS

The user shall not make any changes or modifications to the equipment unless authorized by the Installation Instructions or User's Manual. Unauthorized changes or modifications could void the user's authority to operate the equipment.

CLASS B DIGITAL DEVICE STATEMENT

This equipment has been tested and found to comply with the limits for a Class B digital device, as defined by FCC Rules Part 15.105. The Class B Digital Device statement can be viewed at:

<https://customer.resideo.com/en-US/support/residential/codes-and-standards/FCC15105/Pages/default.aspx>

FCC / IC STATEMENT

This device complies with Part 15 of the FCC Rules, and Industry Canada's license-exempt RSSs. Operation is subject to the following two conditions: (1) This device may not cause harmful interference, and (2) This device must accept any interference received, including interference that may cause undesired operation.

Cet appareil est conforme à la partie 15 des règles de la FCC et exempt de licence RSS d'Industrie Canada. Son fonctionnement est soumis aux conditions suivantes:

(1) Cet appareil ne doit pas causer d'interférences nuisibles. (2) Cet appareil doit accepter toute interférence reçue y compris les interférences causant une réception indésirable.

RF EXPOSURE

Warning – The antenna(s) used for this device must be installed to provide a separation distance of at least 7.8 inches (20 cm) from all persons and must not be co-located or operating in conjunction with any other antenna or transmitter except in accordance with FCC and ISED multi-transmitter product procedures.

MISE EN GARDE

Exposition aux Fréquences Radio : La/les antenne(s) utilisée(s) pour cet émetteur doit/doivent être installée(s) à une distance de séparation d'au moins 20 cm (7,8 pouces) de toute personne et ne pas être située(s) ni fonctionner parallèlement à tout autre transmetteur ou antenne, excepté en conformité avec les procédures de produit multi transmetteur FCC et ISED.

REFER TO THE INSTALLATION INSTRUCTIONS FOR THE CONTROL WITH WHICH THIS DEVICE IS USED, FOR DETAILS REGARDING LIMITATIONS OF THE ENTIRE ALARM SYSTEM.

Responsible Party / Issuer of Supplier's Declaration of Conformity: Ademco Inc., a subsidiary of Resideo Technologies, Inc., 2 Corporate Center Drive., Melville, NY 11747, Ph: 516-577-2000

The product should not be disposed of with other household waste. Check for the nearest authorized collection centers or authorized recyclers. The correct disposal of end-of-life equipment will help prevent potential negative consequences for the environment and human health.

Any attempt to reverse-engineer this device by decoding proprietary protocols, de-compiling firmware, or any similar actions is strictly prohibited.

SUPPORT & WARRANTY INFORMATION

For the latest documentation and support, please go to:

www.resideo.com

For the latest warranty information, please go to:

www.security.honeywellhome.com/warranty

The Honeywell Home Trademark is used under license from Honeywell International Inc.
This product is manufactured by Resideo Technologies, Inc. and its affiliates.

resideo

2 Corporate Center Drive, Suite 100

P.O. Box 9040, Melville, NY 11747

© 2020 Resideo Technologies, Inc.

www.resideo.com



800-25229B 2/19 Rev B