

This wireless passive infrared motion sensor is intended for use with Honeywell controls that support SiX™ series devices.

Mounting Location

- The optimal range is obtained at a mounting height of 7' 6" (2.3 m).
- Allow a clear line-of-sight to all areas to protect.
- Do not directly face windows.
- Avoid close proximity to moving machinery, fluorescent lights, and heating/cooling sources.
- For use in applications with pets up to 80 pounds (36 kilograms).

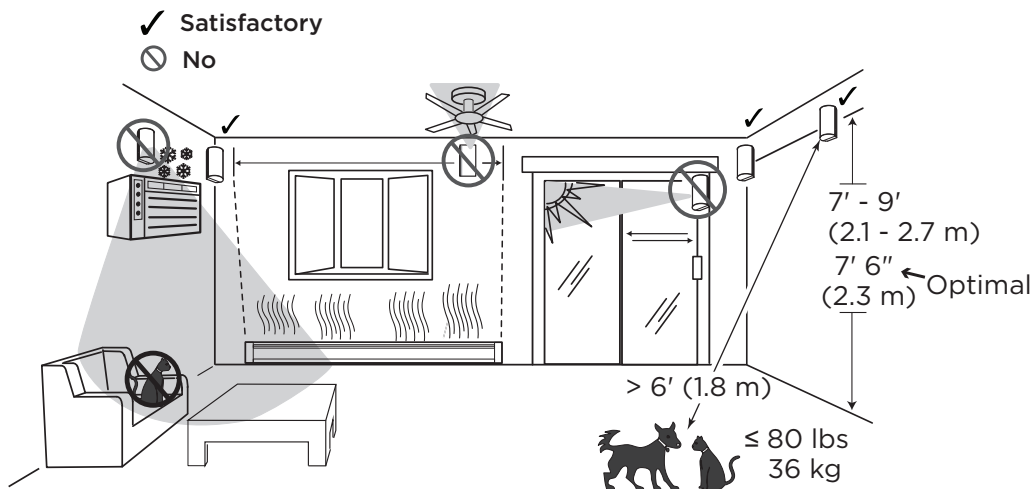

In Applications with Animals:

- Mount with the center of the device at 7.5 feet (2.3m)
- Mount where pet cannot come within 6 feet (1.8m) of the sensor by climbing on furniture, stairs, boxes or other objects.
- Test each installation to determine exact level of animal immunity; levels vary based on environmental differences and the amount of heat radiated by an animal.

Mounting Options

NOTE: before mounting the device permanently, conduct Go/No Go tests (see controller's instructions) to verify adequate signal strength and adjust the device location and orientation as necessary.

The SIXPIR can be mounted on the wall or in corners:

- **[A]** = Wall mounting holes.
- **[B]** = Corner mounting holes.
- The rear tamper plate **MUST** be mounted to a stud, solid wood, or with a robust wall anchor.

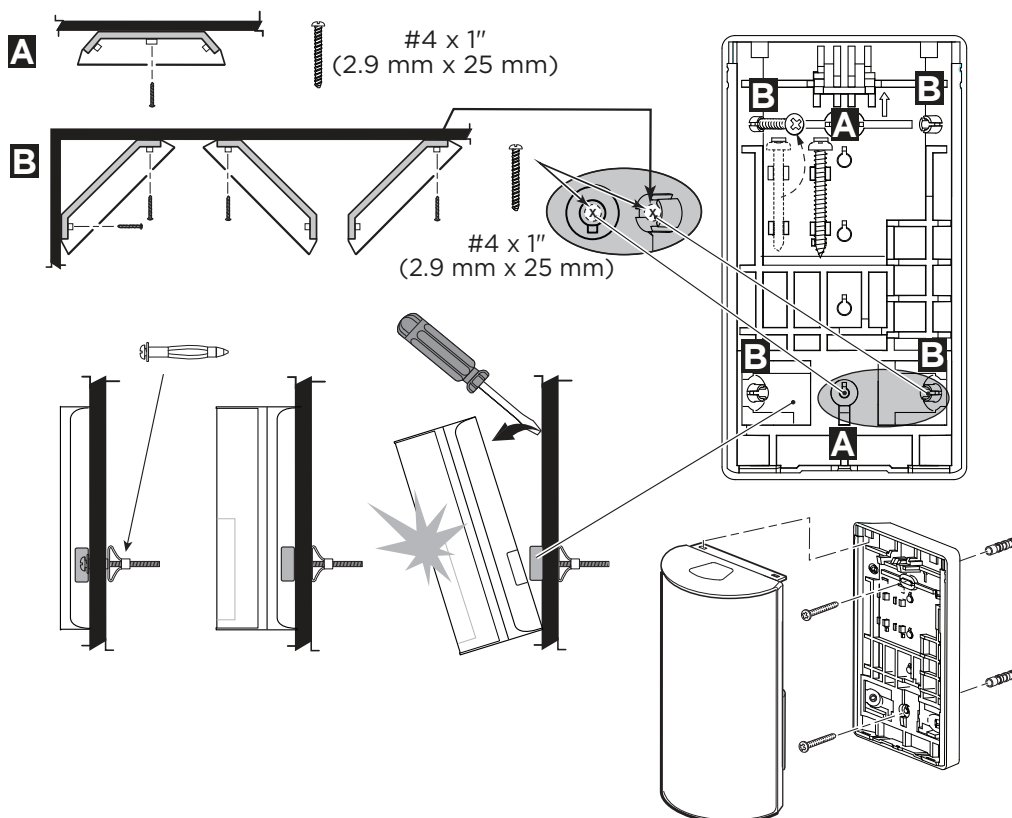

Enroll the SIXPIR

The SIXPIR can be enrolled and programmed before or after installation.

Press down on the top latch and separate the front and back covers.

1. Set the *Lyric Controller* in Programming Mode and go to Zone Programming. Select Add New, then Serial Number.
2. Remove the battery tab to activate and begin the enrollment process.
3. The green LED beneath the battery flashes during enrollment.*
 - The device sends its unique MAC ID (Serial Number) and Services information to the controller.
 - The controller registers the device and displays the transmitter data on screen.
4. Enrollment is confirmed when the LED is ON for 3 seconds and the controller beeps.
5. Trigger the device tamper switch again to complete enrollment.
6. Press SAVE.

***NOTE:** Enrollment time varies depending on the signal strength between the device and the controller and may take up to about 20 seconds.

If the sensor is not successfully enrolled during the enrollment period, the LED turns off and the device enters a sleep mode. Activate a tamper or remove and reinsert the battery to restart the enrollment process.

The device can also be manually enrolled. See the Controller's Programming Guide for details.

After enrolling, update the SiXPIR firmware (via the Controller) to ensure the latest version is used. See the Controller's instructions.

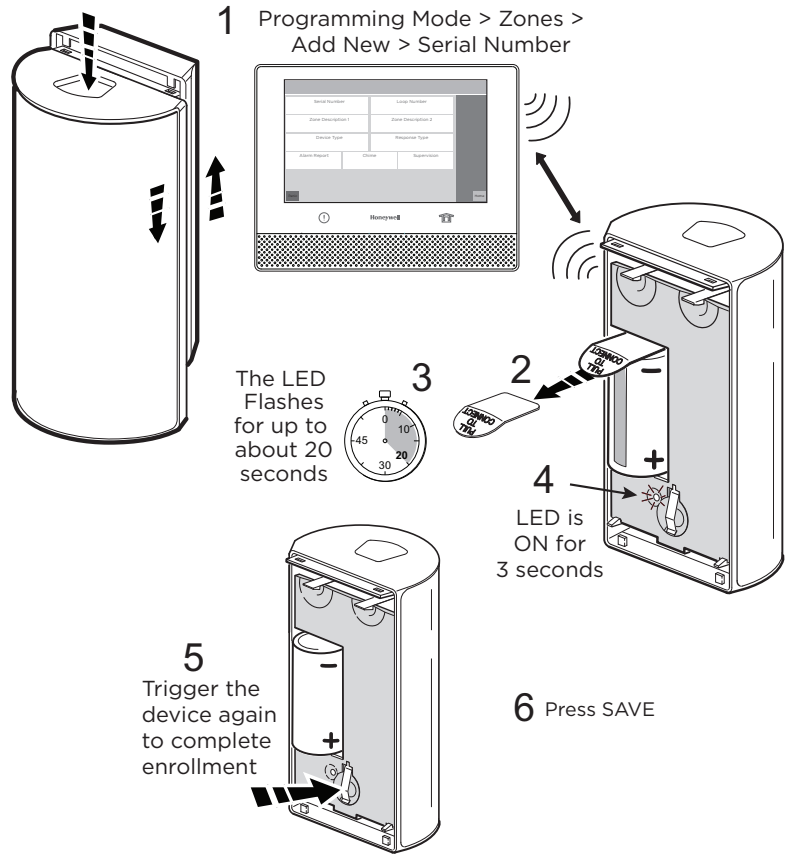

NOTE: Once enrolled in a system, the sensor cannot be used with another controller until it is removed from the current controller. See the Controller's instructions for details.

Follow instructions in the Controller's programming guide to program the sensor in the system.

Pet Immunity is selectable: Off or Up to 80 lbs (36 kg).

Walk Test the SIXPIR

After power up and enrollment, activate the Test Mode with the controller (see controller's instructions) or use the Flashlight Feature.

NOTE: the system must be in **disarmed** mode for the 10 minute Test mode to begin.

Walk through the detection area and observe the LED.

Test Mode is active for 10 minutes, then automatically exits test mode, disables the LED and enters normal operation mode.

To restart the 10 minute Test Mode, use the flashlight feature (see the following section).

Activate the Test Mode

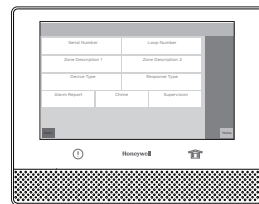

from the controller
OR
using the Flashlight Feature

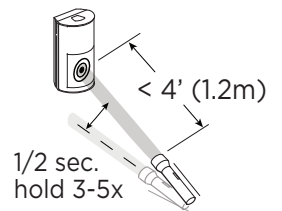

10 minutes

Flashlight Feature

The flashlight feature is only available for the first 24 hours after the first power up, or until the system is first armed. **This feature is no longer available after the first system arming.**

Each time the flashlight features is used, and the system is disarmed, the walk test timer restarts for 10 minutes.

1. Use a flashlight with a bright light beam, and stand within 4' (1.2 m) of the sensor.
2. Swing the light beam past the sensor Lens 3-5 times, holding the beam on the window for 0.5 second each pass.

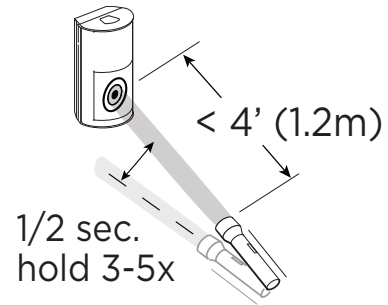

NOTE: the flashlight feature only initiates or restarts the Test Mode and does not change any other sensor settings.

Detection Patterns

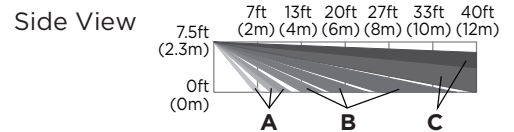
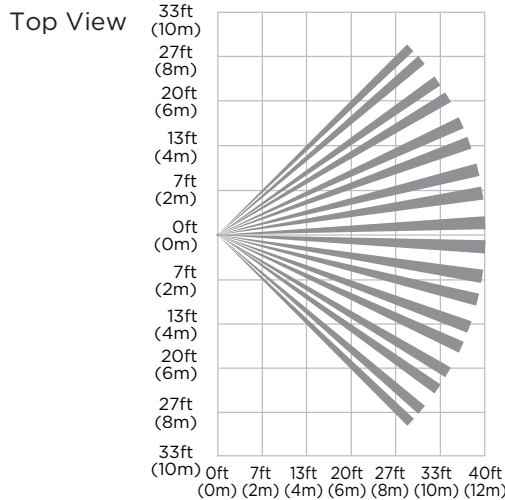

Zones

A	18 Lower
B	46 Intermediate
C	36 Long

Battery Replacement

- Press the latch at the top of the device and slide the front cover down to remove it.
- Remove the battery and wait 10 seconds, then insert a new battery. Recommended batteries: Panasonic CR123A Honeywell 466 Duracell DL123 Duracell DL123A
- Place the front and back covers together and slide the front cover upward as shown.

BATTERY CAUTION: Risk of fire, explosion and burns. Do not recharge, disassemble, heat above 212° F (100° C) or incinerate. Dispose of used batteries properly. Keep away from children.

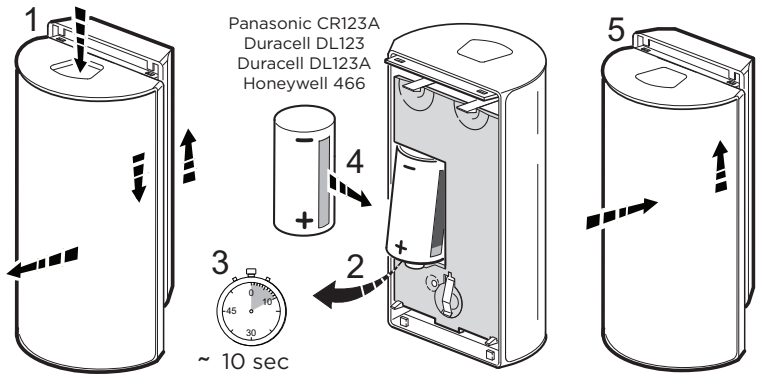

Specifications

Range: 40' x 56' / 12 m x 17 m

Wall Mounting Height: 7' – 9' (2.1 m – 2.7 m); Optimal 7'6" (2.3 m)

Battery: 1 x 3V, Lithium; Panasonic CR123A, Duracell DL 123A, Duracell DL 123, Honeywell 466

RF Frequency: 2.4GHz

Tamper: Cover and Wall – reported separately to panel.

Operating Temperature: 32° – 122° F / 0° – 50° C (Agency Compliance 32° – 120° F / 0° – 49° C)

Relative Humidity: 95% max. (Agency Compliance - 93% max.), non-condensing

Dimensions: 4.13" H x 2.38" W x 1.61" D / 105 mm H x 60.4 mm W x 41 mm D

Weight: 3.97 oz / 112.67g (net weight)

Approval Listings

FCC / IC

cETLus Listed

Conforms to UL 639

Certified to ULC-S306-03



Other Standards:

SIA-PIR-01

RoHS

The product must be tested at least once each year.

FEDERAL COMMUNICATIONS COMMISSION & INDUSTRY CANADA STATEMENTS

The user shall not make any changes or modifications to the equipment unless authorized by the Installation Instructions or User's Manual. Unauthorized changes or modifications could void the user's authority to operate the equipment.

FCC / IC STATEMENT

This device complies with Part 15 of the FCC Rules, and RSS-210 of Industry Canada. Operation is subject to the following two conditions: (1) This device may not cause harmful interference, and (2) This device must accept any interference received, including interference that may cause undesired operation.

Cet appareil est conforme à la partie 15 des règles de la FCC & de RSS-210 des Industries Canada. Son fonctionnement est soumis aux conditions suivantes: (1) Cet appareil ne doit pas causer d'interférences nuisibles. (2) Cet appareil doit accepter toute interférence reçue y compris les interférences causant une réception indésirable.

RF EXPOSURE

Warning – The antenna(s) used for this device must be installed to provide a separation distance of at least 7.8 inches (20 cm) from all persons and must not be co-located or operating in conjunction with any other antenna or transmitter except in accordance with FCC multi-transmitter product procedures.

Mise en Garde

Exposition aux Fréquences Radio: L'antenne (s) utilisée pour cet émetteur doit être installée à une distance de séparation d'au moins 7,8 pouces (20 cm) de toutes les personnes.

Support and Warranty

REFER TO THE INSTALLATION INSTRUCTIONS FOR THE CONTROL WITH WHICH THIS DEVICE IS USED, FOR DETAILS REGARDING LIMITATIONS OF THE ENTIRE ALARM SYSTEM.

For the latest documentation and online support information, please go to:
<https://mywebtech.honeywell.com/>

For the latest warranty information, please go to:
www.honeywell.com/security/hsc/resources/wa.

For patent information, see www.honeywell.com/patents



MyWebTech



Warranty



Patents