

Installation & Setup Guide

GENERAL INFORMATION

This wireless multi-criteria heat detector is intended for use with Controls that support PROSiX™ series devices.

To remove the mounting bracket, turn the top of the detector 15 degrees counterclockwise and separate the mounting bracket and top cover.

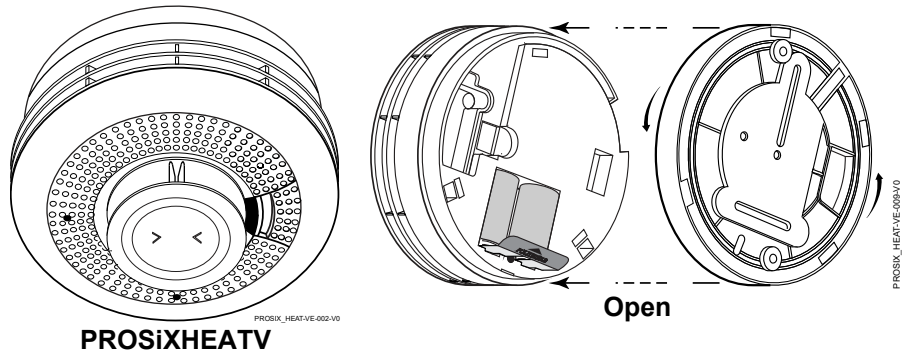

ENROLLMENT

Enroll the device using AlarmNet 360. When prompted for MAC ID, activate the device by pulling the battery tab or, if already powered, press the Test Button. It enrolls into a single zone for heat detection.

If the detector is not successfully enrolled during the enrollment period, the LED turns off and the device powers down. Activate the tamper or press the Test Button to restart the enrollment process.

NOTES: Enrollment time varies depending on the signal strength between the device and the Control Panel. Once enrolled in a system, the detector cannot be used with another system until it is removed from the current one. See the Control Panel's instructions for details.

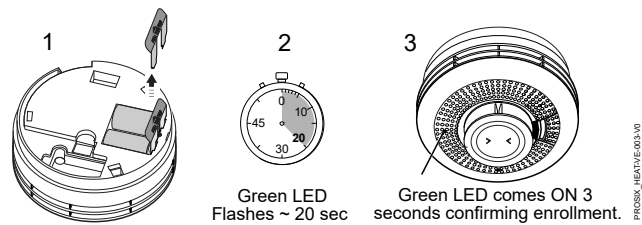

PROGRAM

Consult the Control Panel's instructions to program the device in the system. This detector reports the following signals to the Control Panel:

- Heat detection
 - Heat Alarm when temperature of 135° F (57° C) or greater
 - Rate-of-Rise Alarm when temperature is >104° F (40° C) @ 15° F/minute (8.33° C/minute).
- End-of-Life
- Base Tamper: It sends a tamper signal to the control when the head is removed from its base.
- Supervision: 200 second check-in compatible.
- Signal and battery Strength: Signal and battery strength information are sent with every communication to the panel.

NOTE: If programmed in the Control to operate in One-Go-All-Go mode, all heat detectors programmed as One-Go-All-Go in the system will sound on alarm.

TAMPER

When the detector is removed from its base, it sends a tamper signal to the Control. **OPTIONAL:** The detector can be made tamper-proof to prevent unauthorized removal from its base. Break off the small pillar on the base as shown. This causes the detector to latch to the base. From this point on, to remove the detector from its base, you must use a small screwdriver to release the catch (push the catch towards the base) and twist the detector counterclockwise. A screw can be added to prevent removal from the base.

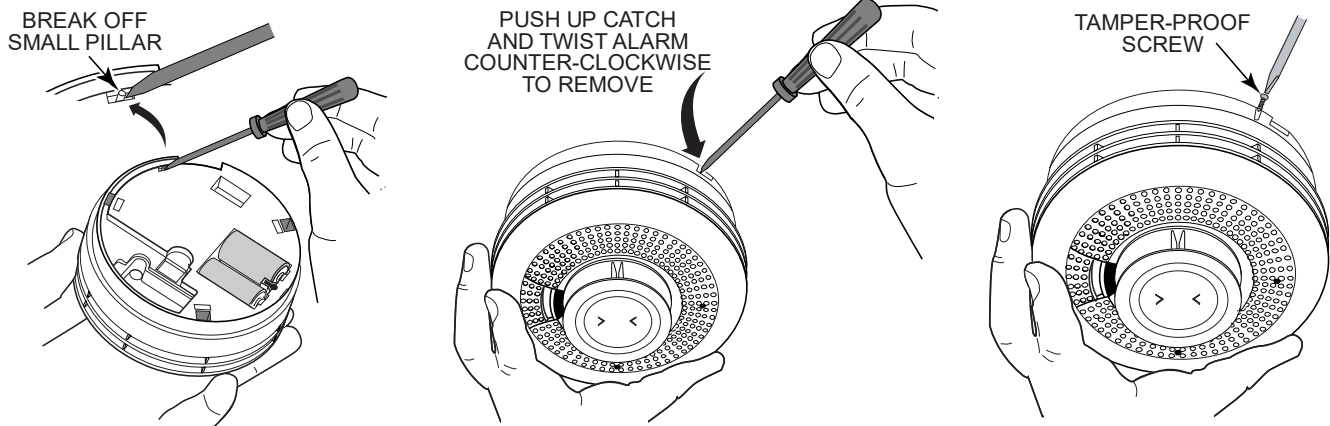

MOUNTING

Refer to the Limitations of Fire Alarm Systems (P/N 800-15144) for detailed information on detector spacing, placement zoning and special applications. Copies of this document are available at: www.resideo.com

NOTE: Before mounting the detector permanently, conduct a Walk test (see control's instructions) to verify adequate signal strength and adjust the device location and orientation as necessary.

The detector can be mounted on the ceiling or on the wall (if local ordinances permit). Select a location and mount using the included mounting hardware.

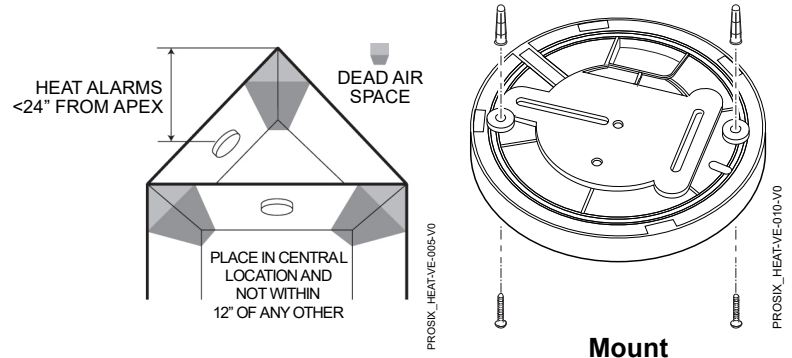

DO NOT attach the detector to removable ceiling panels. Attach the detector across panel support as shown on the accompanying figure.

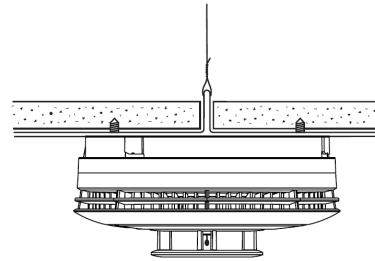

TESTING

The detector should be tested immediately after installation and at least once a year.

Recommended: Notify the Central Station that the heat detector is undergoing tests, so they do not dispatch authorities.

After enrolling, verify adequate signal strength by conducting a sensor test (see the Control Panel's instructions) with the device in its intended mounting location. Adjust the device location and orientation as necessary.

Tests and testing methods:

There is no specific Test Mode that needs to be initiated to test Heat, or Rate-of-Rise. These can be applied to the detector at any time as a test.

- Test Button – When the Test Button is held down, the unit initiates a test on the heat sensor, End-of-Life, and battery. If all tests pass, it sounds a normal alarm and sends alarm signal to the Control. However, if one of these tests fails, it sends a trouble signal to the Control and provides fail status on the yellow led and sounder. The Test Button is also used to silence or Hush the detector. To Hush the detector, press and release the large Test Button. Only the detector that initiated the alarm can be Hushed by the Test Button. Other detectors that sound with One-Go-All-Go must be silenced by the Control by entering a disarm command. Entering a disarm command to the Control also silences all detectors that are sounding without needing to Hush any heat detector. See the LED and Sounder Indication Chart on the next page.
- Direct Heat Test (hair dryer 12" or further from the detector).
- 135° F fixed Heat Detection
- Rate-of-Rise >104° F (40° C) @ 15° F/minute (8.33° C/minute)

CAUTION: The detector alarms when 135° F is exceeded and restore when it falls below 135° F. However, the thermistor is damaged at 195° F and the integrity of the detector itself is compromised and needs to be replaced.

PRESS AND HOLD
TEST BUTTON

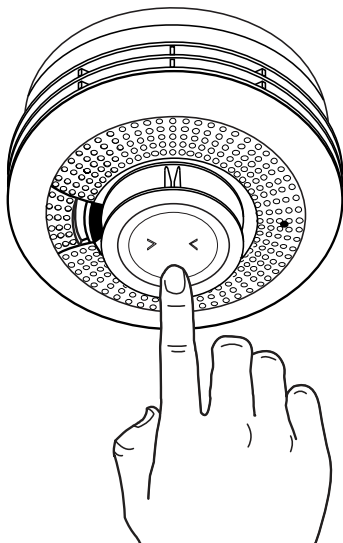

BLOW HOT AIR INTO
HEAT SENSOR AREA

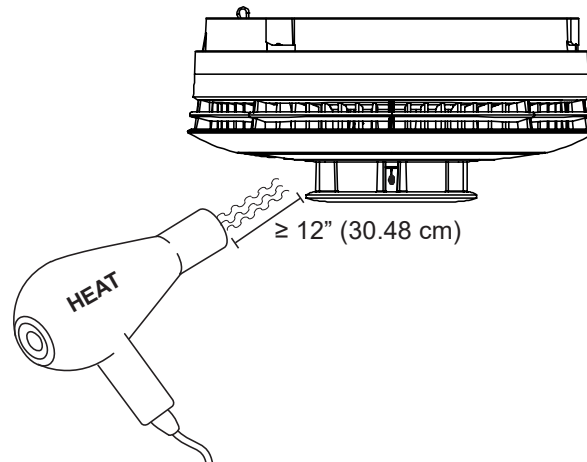

LEDS AND SOUNDER

The PROSIXHEATV has one green LED and a separate bi-color (red and yellow) LED with an 85dB sounder. Refer to the following table below for operation of these features.

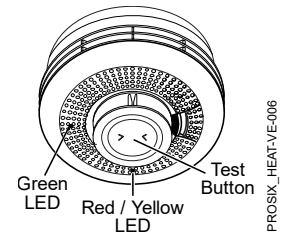

LED and Sounder Indication Chart

Normal Operation	Action	Green LED	Red LED	Yellow LED	Sounder	Reaction
Power Up	Pull Battery Tab	1 Flash	1 Flash	1 Flash	Off	
Enrollment into System	Program into Control	Rapid flashing up to 30 seconds, Then on 3 seconds	Off	Off	Single Chirp	Install into System
Delete from System	Delete from Control	Rapid flashing for 5 seconds	Off	Off	Off	Uninstall from system
Processing Control Queries		Slow flashing	Off	Off	Off	
Tamper	Remove from base	Slow flash for 10 minutes	Off	Off	Off	
Standby - Normal		1 flash every 60 seconds	Off	Off	Off	
Sensing Heat	Fire Condition	Off	Rapid flashing	Off	Temporal 3	Evacuate Premises
One-Go-All-Go	Fire / CO Alarm from Control	Off	Off	Off	Fire Temporal 3 / CO Temporal 4	Evacuate Premises
Alarm Hush	Action	Green LED	Red LED	Yellow LED	Sounder	Reaction
Silence Sounding Alarm	Press & Release Button	Off	1 flash every 8 seconds	Off	Off for 10 mins	
Silence Low Battery	Press & Release Button	Off	Off	Off for 12 hours	Beep once per hour for 12 hours	Replace both batteries
Silence Faulty Sensor (only possible once)	Press & Release Button	Off	Off	2 flashes every 48 seconds	Off for 12 hours	Replace unit
Silence End of Life (up to 30 days)	Press & Release Button	Off	Off	Off for 72 hours	Off for 72 hours	Replace unit
Self-Diagnostics	Action	Green LED	Red LED	Yellow LED	Sounder	Reaction
Low Battery	Automatic every 16 minutes	Off	Off	1 flash every 48 seconds	1 beep with 1 flash	Replace both batteries
Faulty Heat Sensor	Automatic every second	Off	Off	2 flashes every 48 seconds	2 beeps with 2 flashes	Replace unit
End of Life	Automatic every 4 hours	Off	Off	3 flashes every 48 seconds	3 beeps with 3 flashes	Replace unit
Maintenance	Automatic every 16 seconds	Off	Off	4 flashes every 48 seconds	Off	Clean unit; see Cleaning section
Test Button	Action	Green LED	Red LED	Yellow LED	Sounder	Reaction
Detector Status Good – Normal Alarm	Press & Hold Button	Off	Rapid flashing	Off	Temporal 3	Release button
Low Battery	Press & Hold Button	Off	Off	1 flash then rapid flashing	1 beep then Temporal 3	Replace both batteries
Faulty Sensor	Press & Hold Button	Off	Off	2 flashes then rapid flashing	2 beeps only	Replace unit
End of Life	Press & Hold Button	Off	Off	3 flashes then rapid flashing	3 beeps then Temporal 3	Replace unit
Maintenance	Press & Hold Button	Off	Off	4 flashes then rapid flashing	4 beeps then Temporal 3	Clean unit; see Cleaning section
Alarm Memory	Action	Green LED	Red LED	Yellow LED	Sounder	Reaction
24 Hour Memory	After Alarm	Off	2 flashes every 48 seconds for 24 hours	Off	Off	Press & Hold Button for Long Term Memory
Long Term Memory	Press & Hold Button	Off	Rapid flashing	Off	Rapid chirping	Memory is reset after releasing the test button

CLEANING

Recommended: To prevent unwanted alarms, notify the Central Station that the heat detector system is undergoing maintenance before cleaning the detector.

To clean the detector, carefully vacuum the side vents all the way around, then, wipe them with a clean damp cloth and dry thoroughly.

Do NOT attempt to take the detector apart. This could result in damaging the unit.

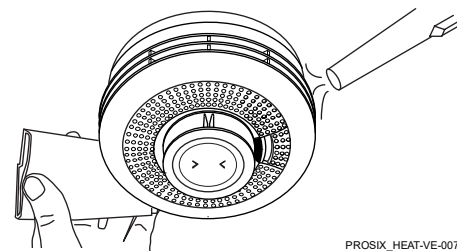

Cleaning

BATTERY REPLACEMENT

1. Twist the front cover counterclockwise 15 degrees and separate it from the mounting bracket.
2. Remove both batteries and wait 10 seconds.
3. Press the test button, then insert two new recommended batteries:
 - Panasonic CR123A
 - Resideo 466

NOTE: Do not mix old and new batteries, battery types or manufacturers.

4. Reattach to the detector to the mounting plate.

BATTERY CAUTION: Risk of fire, explosion and burns. Do not recharge, disassemble, heat above 212° F (100° C) or incinerate. Dispose of used batteries properly. Keep away from children

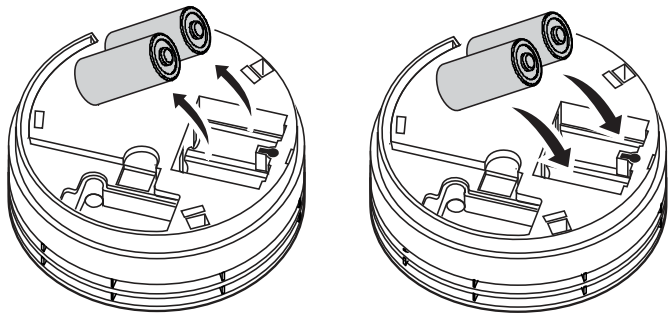

PROSiX_HEAT-VE-008-V0

Replace Batteries

PROSiX™ Series transmitters draw quick bursts of current during transmission, then sit idle with very nominal current draw. Most batteries are not designed for this type of use, therefore, only batteries listed as compatible should be used if the expected battery life is to be attained. Each transmitter's Installation Instructions has listed compatible battery manufacturers and their part numbers. When other non-approved batteries are used, the quick bursts of current draw kill the battery cells prematurely causing them to go low in a matter of months and can also cause unpredictable results. Other low-quality batteries have not been UL tested and pose a safety hazard if used.

SPECIFICATIONS

- Heat Detection:** 135° F (57° C) or greater +/- 5° F
- Rate of Rise:** >104° F (40° C) @ 15° F/minute (8.33° C/minute).
- dB Rating:** >85dBA (Minimum) at 9ft
- Batteries:** Two 3V Lithium; Panasonic CR123A, Resideo 466
- RF Frequency:** 2.4GHz
- Tamper:** Base Tamper
- Operating Temperature:** 40° to 100° F / 4.4° to 37.7° C
- Relative Humidity:** 15% to 95% max, non-condensing
- Maximum Spacing:** 50ft x 50ft (refer to National Fire Alarm Code Standard NFPA 72 for application requirements)
- Dimensions:** 4.70 in. Diameter x 2.31 in. Thick / 11.95 cm Diameter x 5.81 cm Thick

Approval Listings

- FCC / IC
- ETL Listed – Conforms to UL 521
- cETL Listed – Certified to CAN/ULC S530
- Other Standards: State of California requirement – free of substances that may cause cancer. Prop 65 US.
- NFPA 72

REFER TO THE INSTALLATION INSTRUCTIONS FOR THE CONTROL WITH WHICH THIS DEVICE IS USED, FOR DETAILS REGARDING LIMITATIONS OF THE ENTIRE ALARM SYSTEM.

FEDERAL COMMUNICATIONS COMMISSION (FCC) & INDUSTRY CANADA (IC) STATEMENTS

The user shall not make any changes or modifications to the equipment unless authorized by the Installation Instructions or User's Manual. Unauthorized changes or modifications could void the user's authority to operate the equipment.

L'utilisateur ne doit en aucun cas apporter des modifications à l'appareil, sauf en cas d'autorisation dans les instructions d'installation ou le manuel de l'utilisateur. Toute modification non autorisée risque de faire perdre à l'utilisateur son droit d'utiliser l'appareil.

CLASS B DIGITAL DEVICE STATEMENT

This equipment has been tested and found to comply with the limits for a Class B digital device, as defined by FCC Rules Part 15.105. The Class B Digital Device statement can be viewed at: <https://customer.resideo.com/en-US/support/residential/codes-and-standards/FCC15105/Pages/default.aspx>

FCC / IC STATEMENT

This device complies with Part 15 of the FCC Rules, and Industry Canada's license-exempt RSSs. Operation is subject to the following two conditions: (1) This device may not cause harmful interference, and (2) This device must accept any interference received, including interference that may cause undesired operation.

Cet appareil est conforme à la partie 15 des règles de la FCC et exempt de licence RSS d'Industrie Canada. Son fonctionnement est soumis aux conditions suivantes: (1) Cet appareil ne doit pas causer d'interférences nuisibles. (2) Cet appareil doit accepter toute interférence reçue y compris les interférences causant une réception indésirable.

RF EXPOSURE WARNING – The antenna(s) used for this device must be installed to provide a separation distance of at least 7.8 inches (20 cm) from all persons and must not be co-located or operating in conjunction with any other antenna or transmitter except in accordance with FCC multi-transmitter product procedures.

Mise en Garde Exposition aux Fréquences Radio: L'antenne (s) utilisée pour cet émetteur doit être installée à une distance de séparation d'au moins 7,8 pouces (20 cm) de toutes les personnes et ne pas être située(s) ni fonctionner parallèlement à tout autre transmetteur ou antenne, excepté en conformité avec les procédures de produit multi transmetteur FCC et ISED

Responsible Party / Issuer of Supplier's Declaration of Conformity: Ademco Inc., a subsidiary of Resideo Technologies, Inc., 2 Corporate Center Drive., Melville, NY 11747, Ph: 516-577-2000

The product should not be disposed of with other household waste. Check for the nearest authorized collection centers or authorized recyclers. The correct disposal of end-of-life equipment will help prevent potential negative consequences for the environment and human health. Any attempt to reverse-engineer this device by decoding proprietary protocols, de-compiling firmware, or any similar actions is strictly prohibited.

For the latest documentation, support and warranty information, please go to: www.resideo.com

This product is manufactured by Resideo Technologies, Inc. and its affiliates.



R800-25945A 1/21 Rev A

resideo

2 Corporate Center Drive, Suite 100
P.O. Box 9040, Melville, NY 11747
 © 2021 Resideo Technologies, Inc.
www.resideo.com