

1 LOCATION / EMBLACEMENT / UBICACIÓN

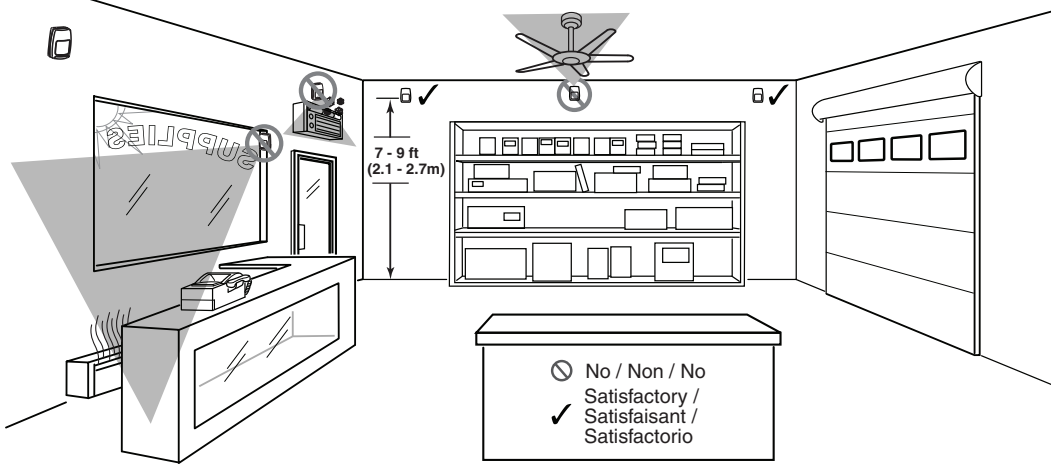

2 OPEN / OUVERTURE / ABRIR

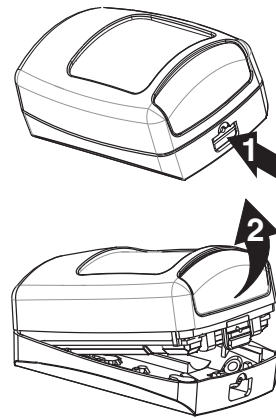

3 CONNECT THE BATTERY / METTRE LES PILES EN PLACE / CONEXIÓN DE LAS BATERIAS

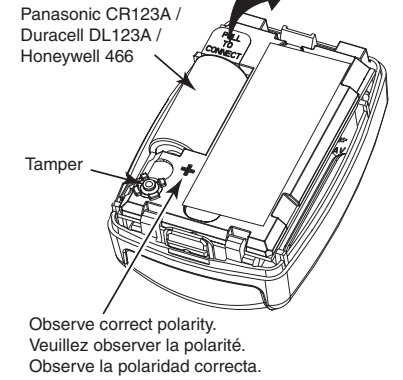

4 ENROLL THE SENSOR, CONDUCT GO / NO GO TEST, AND PERFORM WALK TEST / ENRÔLEZ LE DÉTECTEUR, EXÉCUTEZ UN TEST "TOUT OU RIEN" ET FAITES UN TEST PAR DÉPLACEMENT / REGISTRE EL SENSOR, REALICE UNA PRUEBA PASA/NO PASA Y UN RECORRIDO DE PRUEBA

See page 2 for more information / Pour plus d'information, consultez la page 2 / Consulte la página 2 para obtener más información

5 MOUNT / MONTAGE / MONTAJE

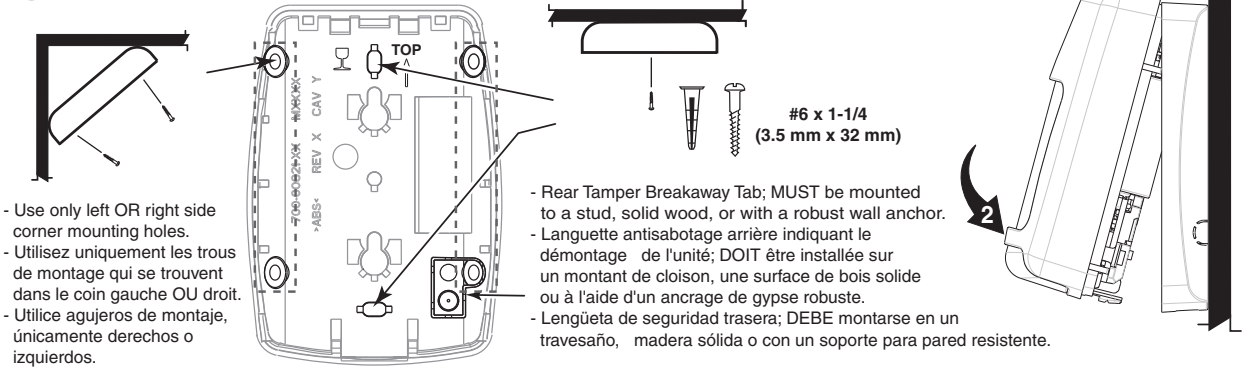

A LENS CHANGE INSTRUCTIONS / INSTRUCTIONS DE REMPLACEMENT DE LAS LENTILLE / INSTRUCCIONES DE CAMBIO DE LENTES

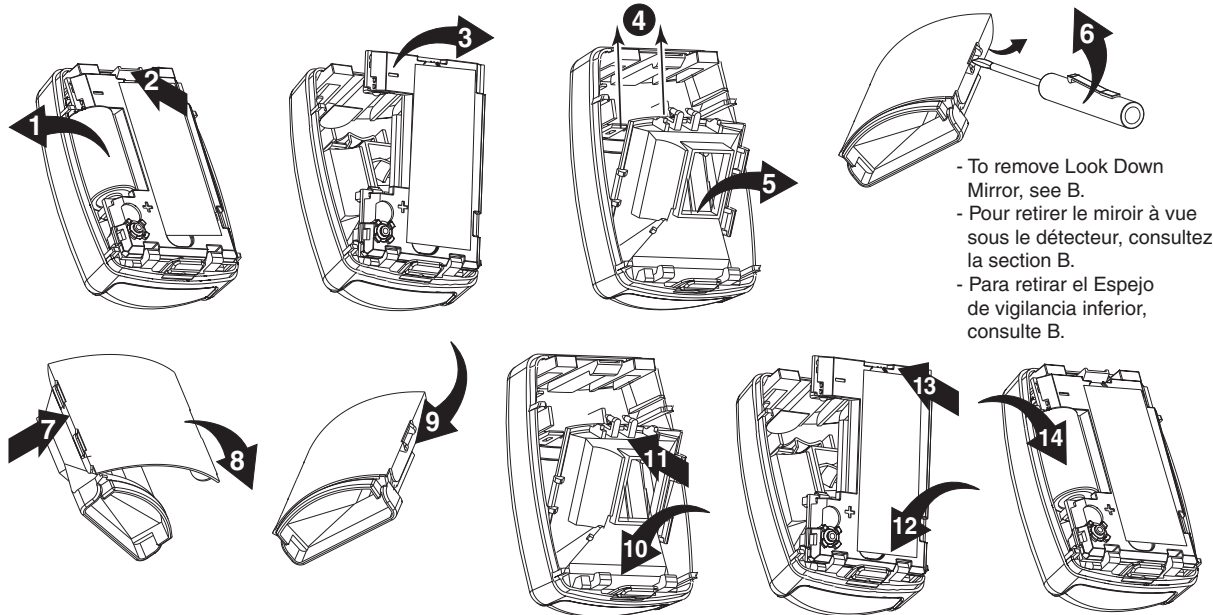

B LOOK DOWN MIRROR REMOVAL AND STORAGE / RETRAIT ET ENTREPOSAGE DU MIROIR À VUE SOUS LE DÉTECTEUR / RETIRO Y ALMACENAMIENTO DEL ESPEJO DE VIGILANCIA ZONA 0

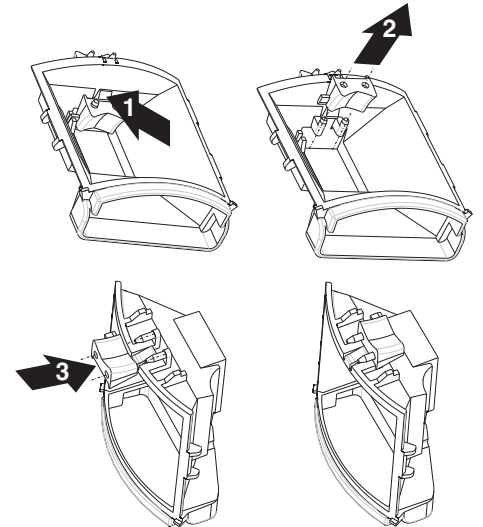

C DETECTION PATTERNS / MODÈLE DE DÉTECTION / PATRONES DE DETECCIÓN

60° / 18m Wide Angle Lens / Objectif Grand-angle / Lente Gran Angular [P/N 5-532-451-01 (Installed)]

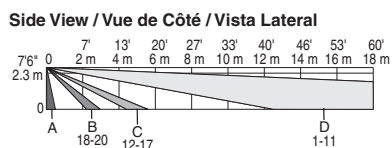
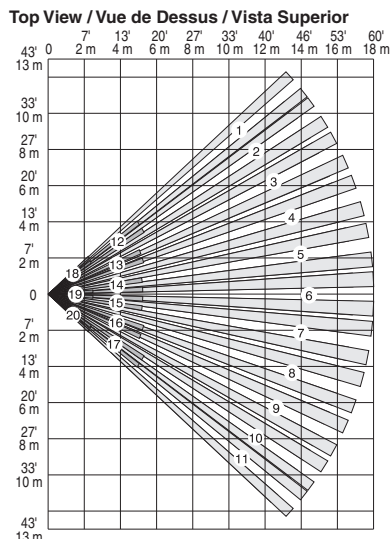

Lens Masking / Masquage de L'Objectif / Enmascaramiento del Lente

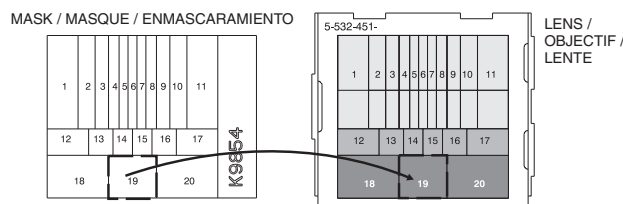

100° / 30 m Long Range Curtain Lens / Objectif Longue Portée / Lente de Largo Alcance [P/N 5-532-384-01 (Included)]

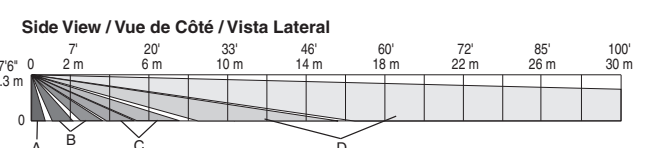
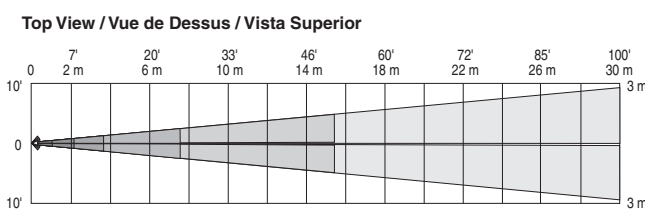

D ACCESSORIES / ACCESSOIRES / ACCESORIOS

SMB-10* (P/N 0-000-110-01)	Swivel Mount Bracket Support de montage pivotant Soporte Giratorio
SMB-10C* (P/N 0-000-111-01)	Swivel Mount Ceiling Bracket Support pivotant pour montage au plafond Soporte Giratorio de Cielo
IS2500-HSLK¹ 35' x 40' (11 m x 12 m)	High Security Lens Kit Kit d'objectif haute sécurité Kit de lentes de alta seguridad
IS2500-PALK² 35' x 40' (11 m x 12 m)	Pet Alley Lens Kit Kit d'objectif avec couloir pour animaux familiaux Kit de lentes inmunes a las mascotas (Pet Alley)

* Not evaluated by UL.
Mounting Height: 1' 7 - 9 ft (2.1 m - 2.7 m)
Hauteur de montage: 2' 4 ft (1.2 m)
Altura de la instalación:

SPECIFICATIONS	SPÉCIFICATIONS	ESPECIFICACIONES	
Power: Battery* (included).	Alimentation : Pile* (incluse).	Alimentación: Batería* (incluida).	1 x 3 V , Lithium / Lítio; Panasonic CR123A / Duracell DL 123A / Honeywell 466
Battery Life, years (typical):	Durée de vie de la pile, en années (typique) :	Duración de las baterías, años (típica):	4
RF Frequency:	Fréquence radio :	Frecuencia de RF:	345 MHz
Operating Temperature: (for indoor use environment)	Température de fonctionnement :	Temperatura de funcionamiento: (para uso bajo techo)	-4° to 131° F (-20° to 55° C)
Relative Humidity, no condensation:	Humidité relative, pas de condensation :	Humedad relativa, sin condensación:	95% max.
Detectable Walk Rate:	Vitesse de marche détectable :	Velocidad de recorrido detectable:	0.7 - 7ft/Sec. (0.2 - 2.0m/Sec.)
Temperature Compensation:	Compensations en Température :	Compensación de Temperatura:	Advanced Dual Slope A doble pente Inclinación dual avanzada

* Battery Caution: Risk of fire, explosion and burns. Do not recharge, disassemble, heat above 212° F (100° C), or incinerate. Dispose of used batteries promptly. Keep away from children.

